

# Berco Product Line

## The Widest Choice



**MOVING YOUR BUSINESS AHEAD**

### The n. 1 in Undercarriage

5,000,000 Track Shoes  
1,000,000 Rollers  
150,000 Track Chains  
250,000 Idlers and Sprockets  
200,000 Tons of product  
12,000 Containers of product

**1**  
**BMU**  
MEDIUM  
RANGE

**2**  
**BMR**  
MINING  
PRODUCTS



A Company of  
ThyssenKrupp  
Technologies

**BERCO** S.p.A.





# MOVING YOUR BUSINESS AHEAD

## YOUR BEST UNDERCARRIAGE VALUE

Since **1920** Berco has offered an innovative, reliable and economical solution to any undercarriage need. Whether for the **original equipment manufacturers (OEM)** or the **aftermarket**, for a **special machine** or a **mini-excavator**, for a **bulldozer** or a **mining excavator**, Berco can offer you the right answer to your specific requirement.

**Superior engineering**, innovative technology, comprehensive know how and state-of-the-art manufacturing guarantee the **total quality** of the products and services offered to you.

**“Original Equipment Quality, Aftermarket Value”**

## THE COMPETENT PARTNER YOU CAN RELY ON

**Custom made solutions** and project engineering support is available upon request.

Our team of engineers can help you **choose or design** the most effective and efficient solution to your specific undercarriage need.

They can help you reduce development and engineering time, tooling expenses and facility costs, while **adding value** to your business.

**“Berco, The choice of the leading OEMs”**



# THE WIDEST CHOICE

## OF UNDERCARRIAGE COMPONENTS AND SYSTEMS FOR TRACK TYPE MACHINES



### TRACK SHOES

- More than **70 different profiles**
- Hot rolled, cast and hot forged shoes
- More than **4,000 configurations**
- Variable width, mud holes, clipped corners, chamfered holes



### IDLERS

- Cast, forged and fabricated (double or single flange) types
- More than **500 configurations**
- Ultra low temperature (-50°) version available



### ROLLERS

- Single flange, double flange and inner flange rollers
- More than **1,500 configurations**
- Ultra low temperature (-50°) version available



### TRACK CHAINS

- Dry, greased, sealed & lubricated chains
- Heavy Duty version
- More than **11,000 configurations**
- Suitable for XR, XL, LGP and TSK undercarriages



### SPROCKETS & SEGMENTS

- Weld-on rim, bolt-on rim, full hub and segmented type
- 3,4,5 and 6 teeth segments
- More than **80 segment configurations**
- More than **600 sprocket configurations**



### SPECIAL APPLICATIONS

- Undercarriage for special applications: large conveyor, pipeline handling, pavers, milling machines, logging equipment, directional drills, mining equipment, etc.

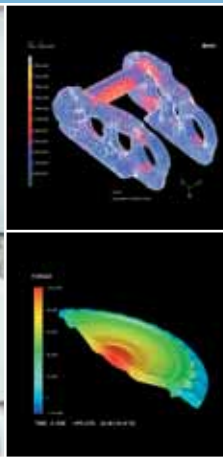

# MAKING A SUPERIOR PRODUCT

## ADDING VALUE TO YOUR BUSINESS

State-of-the-art 3D modeling, **Finite Element Analysis (FEM)** and **Rapid Prototyping** enables to design, optimize and evaluate a component before it is built.

**Artificial Intelligence** techniques are currently being developed to automatically inspect 100% of components. **Reliability Test** on components are carried out to determine life and performance in a variety of field applications.

Berco **Metallurgy Laboratory** employs advanced machines such as an electron microscope with microanalysis, a spectrophotometer, tribometers for wear tests, MTS presses for static and fatigue tests (also at **extreme temperatures** -70°C ÷ 250°C) on materials and components.

Huge efforts are also devoted to the development of **New Materials** and improvement of the **Heat Treating Processes**, to guarantee longer product life and **superior products**.

**Photo-elasticity** and **Strain Gauge** techniques are commonly used for stress and fatigue analysis on individual and assembled components.

**Berco adds value** not only to the products but also to **Your Business**.

ISO 9001



# STATE OF THE ART PRODUCTION

## AUTOMATED PROCESSES AUTOMATIC QUALITY

The entire production process is fully automated and computer controlled via **Computer Manufacturing Technology** systems. This guarantees a highly reliable process and constant quality of the products.

## THE RIGHT PRODUCT AT THE RIGHT TIME

A vast variety of raw materials and **flexible manufacturing** give the competitive advantage of short lead times while matching your specific need. That's what we also call **Customer Satisfaction**.

## HEAT TREATED TO TREAT YOU EVEN BETTER

Quality materials and **state-of-the-art manufacturing** are not enough to guarantee the quality of the finished products. That's why the **heat treating processes** are carried out making sure that all process parameters (temperature gradients, time, quenching temperature, etc.) are constantly monitored online.

Hardening and tempering upgrade mechanical properties for superior wear resistance, stress relieving guarantees perfect geometry and excellent resistance for **longer product life**.



ISO 14001

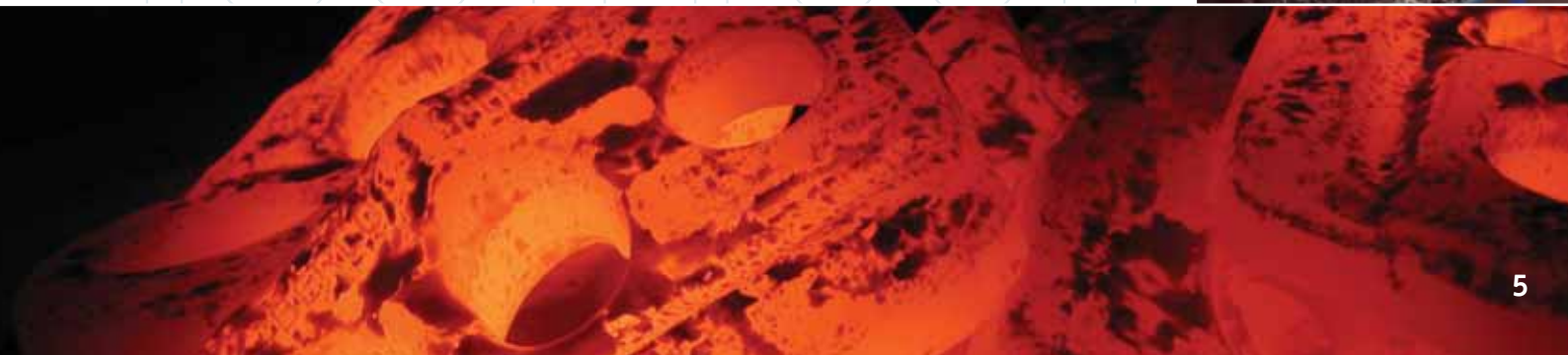

# BMR MEDIUM RANGE

The **Berco Medium Range** offers an innovative, reliable and economical set of solutions to your undercarriage needs, catering for Original Equipment Manufacturers (OEMs), the Aftermarket, bulldozers, excavators, old machines or special designs and providing you with the right answer to your specific requirements.

## THE WIDEST CHOICE

- A complete line of **undercarriage components** for track-type machine classes ranging from **7 to 50 ton** and **140-215.9 mm (5.51"-8<sup>1</sup>/<sub>2</sub>"** chain pitch
- **Dry, greased, sealed** or lubricated chain versions, **heavy duty** chains and **extreme-wear resistant** bushings available upon request, more than **11,000 configurations**
- More than **70 profiles** of track shoes, more than **4,000 configurations**
- Cast, forged or fabricated idler types, more than **500 configurations**
- Single flange, double flange or inner flange rollers, more than **1,500 configurations**
- More than **600 configurations** of sprockets and segments
- **Arctic** (-50°C) version and version for **high-speed** applications
- Undercarriage for **special applications**: conveyor, pipeline handling, milling machines, forest machines, etc...



## TRACK SHOES

- Over **70 different profiles** with Single, Double and Triple Grousers
- Cast steel shoes for **special applications**: swamp type (1), flat type (2), bent ends shoes, polyurethane track shoes (3) and more
- Through hardened and stress relieved to guarantee excellent wear, high strength and resistance to bending and breakage, resulting in longer life



①

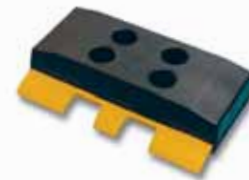

③



②



Undercarriage for sugarcane harvester

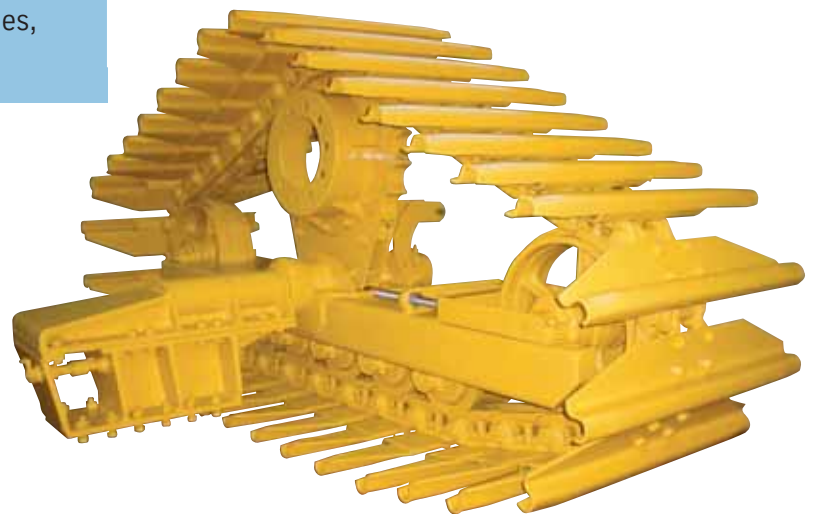

Undercarriage for rice combine harvester

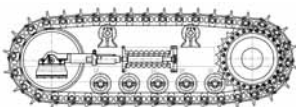

CLASS D3 - D4 B/C  
Pitch: 155.5 mm - 6<sup>1</sup>/<sub>8</sub>"

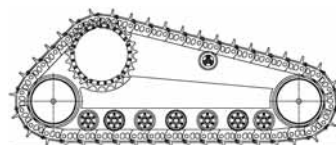

CLASS D5M  
Pitch: 171.5 mm - 6<sup>3</sup>/<sub>4</sub>"

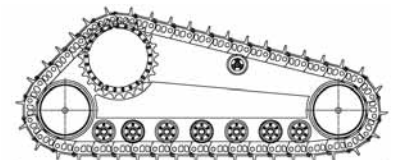

CLASS D6M  
Pitch: 190 mm - 7<sup>1</sup>/<sub>2</sub>"



## BERCO HEAVY DUTY TRACK CHAINS FOR D4-D7 CLASS MACHINES

Heavy duty, sealed & lubricated track chains have been specifically designed for **increased pin & bushing retention**. Track link incorporates **greater pin-to-link and bushing-to-link contact areas** while **additional link wear** material increases component life. D5 and D6 heavy duty chains are also available in the version with **Extreme Wear Resistance Bushings** for maximum life in high abrasion environment.

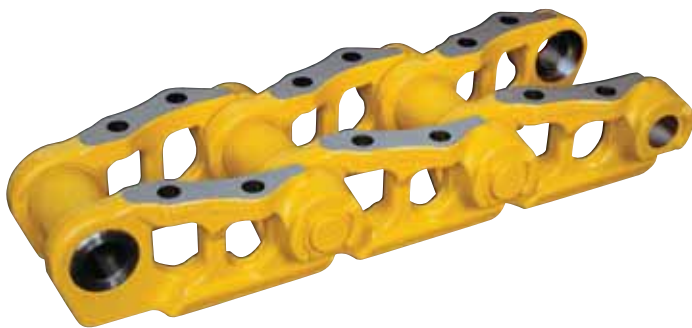

## FORGED SPROCKETS

- Hot forged sprockets for **10-40 ton class excavators** and for **D3-D4 class dozers**
- Nine chain pitch versions from 159.8 to 228.6 mm (6.29"-9")
- **Hot forging** gives optimum internal grain flow and **stronger core resistance**
- Single shot **induction hardened** on entire tooth profile or with differential quenching for excellent resistance to wear and fatigue

## GREASED TRACK CHAINS FOR EXCAVATORS AND HEAVY DUTY APPLICATIONS

A completely **new sealing system**, consisting of a **W shape polyurethane seal**, especially designed to keep grease in joints and abrasive particles out of them

- Internal pin & bushing wear reduction, with consequent **life extension for 20%** and more if compared with the standard sealed chains on the same application
- **Reduction of sneaky tracks phenomenon**, as result of more laterally stable chains, thus reducing wear of related parts, such as links, rollers, guides
- Improved rebuildability of the track chain
- Noise and maintenance **costs reduction** and less machine fuel consumption: improved travelling performances

## FORGED IDLERS

- Hot forged idlers for **15-40 ton class excavators** and for **D6R class dozers**
- Hot forging gives optimum internal grain flow and **stronger core resistance**
- Induction hardened rail surface for **excellent resistance to wear** and fatigue
- Heavier components for improved stability
- No "drum effect" noise resonance

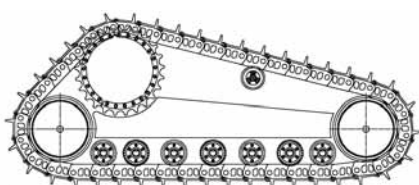

**CLASS D6R**  
Pitch: 203.2 mm - 8"

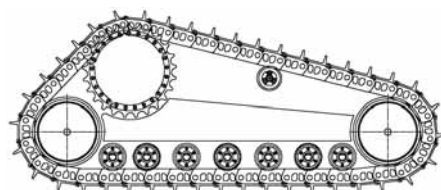

**CLASS D7N/R**  
Pitch: 215.9 mm - 8<sup>1</sup>/<sub>2</sub>"

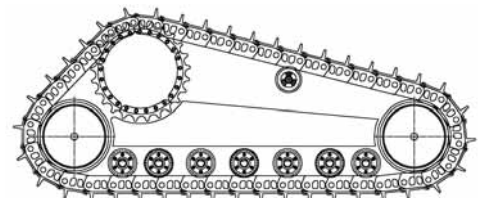

**CLASS D8N/R**  
Pitch: 215.9 mm - 8<sup>1</sup>/<sub>2</sub>"

# BMP MINING PRODUCTS

**Berco Mining Products** offers an efficient, reliable and economical range of solutions for mining operations, catering for the undercarriage needs of open pit mining, quarrying or earthmoving in large-scale land reclamation.

Superior engineering and technology, comprehensive know-how and state-of-the-art manufacturing ensure the total quality of the products and services offered.

Our team of engineers is available to help you choose or design the most effective and efficient solution to your specific undercarriage needs.

## THE WIDEST CHOICE

- A complete line of **undercarriage components** for track-type machine classes ranging **from 50 to 300 ton** and **215.9-350 mm (8½"-13.78") chain pitch**
- Dry, greased, sealed & lubricated chain versions.
- **Arctic** (-50°C) version and track chains with life-time seal groups upon request
- **Forged shoes** for heavy duty applications
- Track chains for **special applications**: large conveyor systems, pipeline handling, etc.



## THE WIDEST CHOICE OF UNDERCARRIAGE FOR EXCAVATORS

- Components for: CAT345, 350, 365, 375, E650, 5080; Demag H65, H85, H95, H121; Case CX800; Hitachi EX550, EX600, EX700, EX750, EX800, EX1000, EX1100, EX1800; Komatsu PC650, PC710, PC750, PC800, PC1100, PC1800; Liebherr R954, R964, R974, R984, R994; Link Belt LS7400; Terex O&K RH30, RH40, RH60, RH90, RH120C; Poclain 300, 400, 600, 1000; Sumitomo SH800 and other machines
- **Chain pitch from 215.9 to 350 mm (8½"-13.78")**



## FORGED SHOES

Forged shoes for **extreme applications**, where greatest mechanical and wear resistance properties are needed



## RH 120C

- Greased unsealed track chain
- **Chain pitch 350 mm (13.78")**
- Double grouser forged shoe, width 800 mm (31½")
- Track roller assembly, single flange, with oil fill plug on collars and locking pins, reinforced shaft dimensions

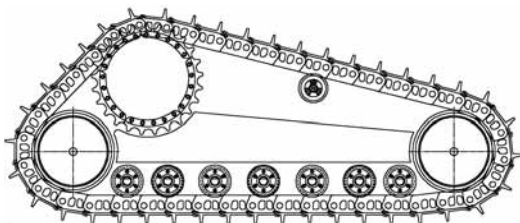

**CLASS D8K - D155**  
Pitch: 228.6 mm - 9"

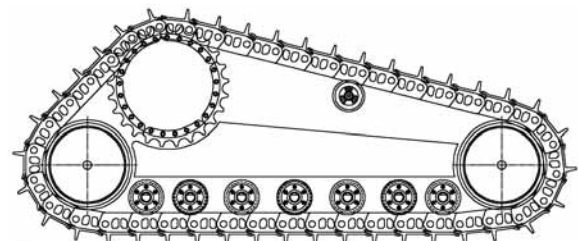

**CLASS D9N/R - D275**  
Pitch: 240 mm - 9.44"



**CLASS D10N/R**  
Pitch 260 mm - 10¼"

**CLASS D375**  
Pitch 280 mm - 11"





## THE WIDEST CHOICE OF UNDERCARRIAGE FOR DOZERS

- Components for: CAT D8, D9, D10, D11 classes; Dresser TD25, TD40; Fiatallis FD30, FD40, FD50; Deere 1050C; Komatsu D135, D155, D275, D355, D375, D455, D475; Liebherr PR751, PR752 and other machines
- **Chain pitch from 215.9 to 317.5 mm (8<sup>1</sup>/<sub>2</sub>"-12<sup>1</sup>/<sub>2</sub>")**
- Track links are forged, quenched and tempered, rail surface induction hardened to increase the wear resistance (HRC>45)
- **Extreme service** single grouser shoes available



## TRACK CHAINS WITH BPR

- For D9L, D9N, D9R, D10N, D10R, D11N, D11R, D275, D375, D455 and D475 machines
- Lubricated track chains with **snap rings** in all joints (BPR)
- **BPR - Berco Pin Retention** - improves operating life of components. The snap rings on the pin ends provide a perfect sealability of the track chains. Side loads can be partially supported by this device
- D10 and D11 are available with **lifetime seal groups**, for applications in which the life of the seal becomes the critical factor for the life of the chain



## LIEBHERR R984C

- Track group, greased, sealed, **chain pitch 280 mm (11")**
- Double grouser shoes, open center, clipped corner, shoe width 750 mm (29<sup>1</sup>/<sub>2</sub>")
- Track roller assembly, single flange
- Bolt-on 12 teeth sprocket rim, diameter 1131 mm (44<sup>1</sup>/<sub>2</sub>")

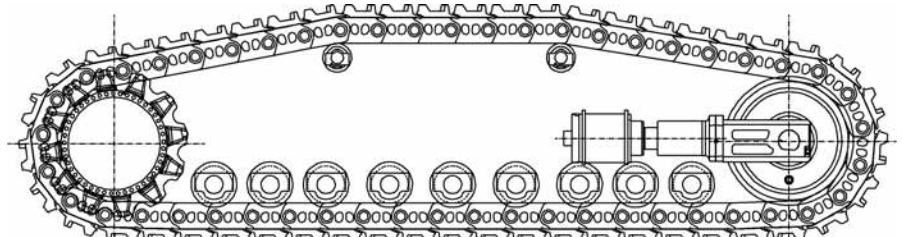
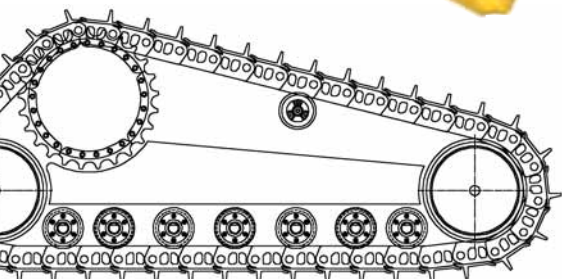
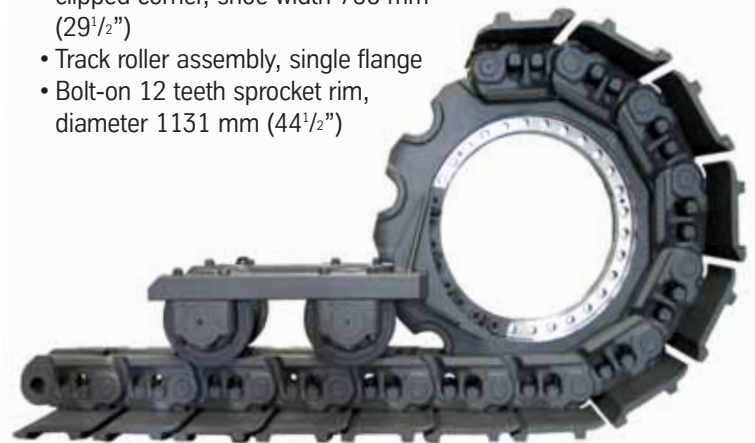

**CLASS D11N/R - D475**  
Pitch 317,5 mm - 12<sup>1</sup>/<sub>2</sub>"

**300 TON CLASS EXCAVATOR**  
Pitch 350 mm - 13.78"

00403.WR432GB00A



All manufacturers's names, numbers, symbols and descriptions are used for reference purposes only. All parts listed are of Berco original production. The specifications and processes described in this brochure are subject to change without notice



Published by Berco Marketing & Communications Dept.



**HEAD OFFICE**

**Western Australia**

**Local Call:** 1300 127 091

**International Call:** +61 (0) 8 9270 8555

**Email:** wasales@transmin.com.au

**Address:** 33-37 Denninup Way Malaga  
Perth, Western Australia, 6090

**Queensland & Northern Territory**

**Local Call:** 1300 800 609

**International Call:** +61 (0) 7 3736 3340

**Email:** qldsales@transmin.com.au

**Address:** 76 Dulacca Street  
Acacia Ridge, Brisbane  
Queensland, 4110

**www.transmin.com.au**